



SÈRIE 1

Exercici 1

Q1 c

Q2 b

Q3 d

Q4 a

Q5 d

Exercici 2

a)

<i>h</i>	<i>c</i>	<i>t</i>	<i>e</i>	<i>a</i>
0	0	0	0	0
0	0	0	1	0
0	0	1	0	0
0	0	1	1	1
0	1	0	0	0
0	1	0	1	1
0	1	1	0	1
0	1	1	1	1
1	0	0	0	0
1	0	0	1	1
1	0	1	0	1
1	0	1	1	1
1	1	0	0	1
1	1	0	1	1
1	1	1	0	1
1	1	1	1	1

b)

$$a = (h+c+t+e)(h+c+t+\bar{e})(h+c+\bar{t}+e)(h+\bar{c}+t+e)(\bar{h}+c+t+e)$$

simplificant

$$a = te + ce + ct + he + ht + hc$$

o també

$$a = c(e+h+t) + e(h+t) + ht$$

c)

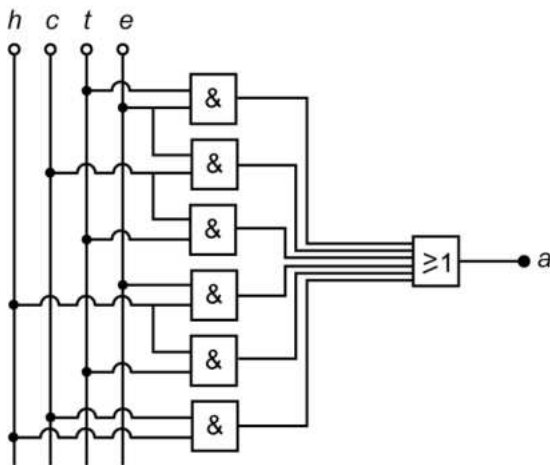

Exercici 3

a)

$$P_{\text{mec}} = mgv \sin(\alpha); \quad P_{\text{elèctr}} = \frac{P_{\text{mec}}}{\eta};$$

$$P_{\text{elèctr}} = \frac{mgv \sin(\alpha)}{\eta} = 218,7 \text{ W}$$

b)

$$\omega_{\text{mot}} = \frac{v}{d/2} = 31,75 \text{ rad/s}$$

$$\Gamma = \frac{P_{\text{mec}}}{\omega_{\text{mot}}} = 5,856 \text{ Nm}$$

c)

$$t = \frac{S}{v}; \quad E_{\text{cons}} = P_{\text{elèctr}} t$$

$$\Delta = \frac{E_{\text{cons}}}{E_{\text{bat}}} = 21,87 \%$$

Exercici 4

a)

$$W = \Delta E_c = \frac{1}{2} m v^2 = 120,6 \text{ kJ}$$

b)

$$E_{\text{cons}} = \frac{W}{\eta};$$

$$m_{\text{ben}} = \frac{E_{\text{cons}}}{\rho_c} = 10,48 \text{ g}$$

c)

$$m_{\text{CO}_2} = \frac{m_{\text{benz}}}{\rho} FE = 31,41 \text{ g}$$

Exercici 5

a)

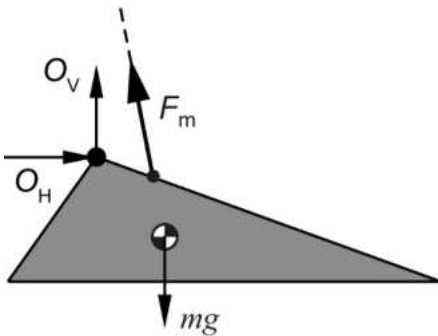

b)

$$\sum M(O) = 0; \quad F_m a - mg b = 0; \quad \rightarrow F_m = 25,17 \text{ N}$$

c)

$$\left. \begin{array}{l} \sum F_{\text{horizontals}} = 0 \quad \rightarrow \quad O_H = F_m \sin(\varphi) \\ \sum F_{\text{verticals}} = 0 \quad \rightarrow \quad O_V + F_m \cos(\varphi) - mg = 0 \end{array} \right\} \begin{array}{l} O_H = 3,938 \text{ N} \\ O_V = -3,286 \text{ N} \end{array}$$

El signe negatiu d' O_V indica que té sentit oposat al dibuixat al diagrama de cos lliure plantejat.

Exercici 6

a)

$$X_{L1} = \omega L_1 = 2\pi f L_1 = 2,199 \Omega$$

b)

$$\tan \varphi = \frac{X_{L1}}{R_1} = 0,44 \rightarrow \varphi = 23,75^\circ \rightarrow \cos \varphi = 0,9154$$

Alternativament (mirar càlculs dels següents apartats)

$$\cos \varphi = \frac{P}{S} = \frac{W_1}{Z A_1^2} = 0,9154$$

o també

$$\cos \varphi = \frac{P}{S} = \frac{W_1}{U_1 A_1} = 0,9154$$

c)

$$Z = \sqrt{R_1^2 + X_{L1}^2} = 5,462 \Omega$$

d)

$$W_1 = R_1 A_1^2; \rightarrow A_1 = \sqrt{\frac{W_1}{R_1}} = 13,78 \text{ A}$$

e)

$$U_1 = Z A_1 = 75,29 \text{ V}$$

SÈRIE 5

Exercici 1

Q1 b

Q2 a

Q3 d

Q4 a

Q5 d

Exercici 2

a)

<i>a</i>	<i>b</i>	<i>c</i>	<i>d</i>	<i>l</i>
0	0	0	0	1
0	0	0	1	1
0	0	1	0	0
0	0	1	1	1
0	1	0	0	0
0	1	0	1	1
0	1	1	0	0
0	1	1	1	1
1	0	0	0	0
1	0	0	1	1
1	0	1	0	0
1	0	1	1	1
1	1	0	0	0
1	1	0	1	1
1	1	1	0	0
1	1	1	1	1

b)

$$I = \bar{a}\bar{b}\bar{c}\bar{d} + \bar{a}\bar{b}\bar{c}d + \bar{a}\bar{b}cd + \bar{a}b\bar{c}\bar{d} + \bar{a}b\bar{c}d + \bar{a}bcd + a\bar{b}\bar{c}\bar{d} + a\bar{b}\bar{c}d + ab\bar{c}\bar{d} + abcd$$

$$I = \bar{a}\bar{b}\bar{c} + d$$

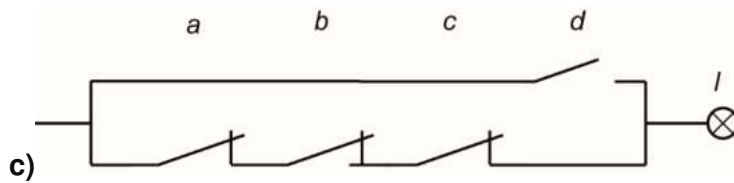

Exercici 3

a)

$$E_{\text{cons}} = m p_c = 78,45 \text{ kWh} = 282,4 \text{ MJ}$$

b)

$$E_{\text{útil}} = E_{\text{cons}} \eta = 69,82 \text{ kWh} = 251,4 \text{ MJ}$$

$$c_e = \frac{p}{E_{\text{útil}}} = 85,93 \times 10^{-3} \text{ € / kWh}$$

c)

$$t = \frac{m}{q_{\text{pèl}}} = 10,11 \text{ h}$$

d)

$$m_{\text{cendra}} = m r_{\text{cendra}} = 105 \text{ g}$$

Exercici 4

a)

$$\tau = \frac{\omega_{\text{roda}}}{\omega_{\text{motor}}} = \frac{Z_1 Z_3 Z_5}{Z_2 Z_4 Z_6} = 92,67 \times 10^{-3}$$

b)

$$\omega_{\text{roda}} = \tau \omega_{\text{mot}} = \tau \frac{n_{\text{mot}} 2\pi}{60}$$

$$v = \omega_{\text{roda}} \frac{d}{2} = 11,65 \text{ m/s} = 41,92 \text{ km/h}$$

c)

$$P_{\text{útil}} = P_{\text{mot}} \eta; \quad \Gamma = \frac{P_{\text{útil}}}{\omega_{\text{roda}}} = 347,8 \text{ Nm}$$

Exercici 5

a)

$$R = \rho \frac{L}{\pi \frac{d^2}{4}} = 14,11 \Omega$$

b)

$$P_{\text{elèctr}} = \frac{U^2}{R}; \quad P_{\text{útil}} = \eta P_{\text{elèctr}} = 3,375 \text{ kW}$$

c)

$$I = \frac{U}{R} = 16,30 \text{ A}$$

d)

$$E_{\text{cons}} = P_{\text{elèctr}} t = 1,875 \text{ kWh} = 6,750 \text{ MJ}$$



Exercici 6

a)

$$E_{\text{útil}} = m c_e \Delta T; \quad E_{\text{cons}} = \frac{E_{\text{útil}}}{\eta} = 7,207 \text{ MJ}$$

b)

$$m_{\text{dutxa}} = \frac{E_{\text{cons}}}{\rho c_{\text{butà}}}; \quad n = \frac{m_{\text{butà}}}{m_{\text{dutxa}}} = 82,73 \text{ dutxes} \rightarrow \text{Es podran fer 82 dutxes de 75 litres}$$

c)

$$p_{\text{dutxa}} = p_{\text{aigua}} V + m_{\text{dutxa}} p_{\text{butà}} / m_{\text{butà}} = 0,2832 \text{ €}$$